

# OmniCure® AC2 Series

## UV Curing Solutions

Applicable for the following UV LED Head models:

Model	Array Curing Width	Part Numbers
AC275-365	75mm	019-00251R
AC275-395	75 mm	019-00236R
AC275F-365	75mm	<a href="#">019-00270R</a>
AC275F-395	75mm	019-00263R
AC2110-365	110 mm	<a href="#">019-00271R</a>
AC2110F-365	110 mm	<a href="#">019-00272R</a>
AC2110-395	110 mm	019-00239R
AC2110F-395	110 mm	019-00254R

## Installation/Reference Guide

**Excelitas Canada Inc.**  
2260 Argentia Road  
Mississauga (ON)  
L5N 6H7 Canada  
+1 905.821.2600  
[www.excelitas.com](http://www.excelitas.com)

035-00589R Rev.5.0

# **OmniCure® AC2 Series**

UV Curing Solutions

---

## **Installation/Reference Guide**

**035-00589R**

**Excelitas Canada Inc. 2015**

**All rights reserved**

No part of this publication may be reproduced, transmitted, transcribed, stored in a retrieval system or translated into any language in and form by any means without the prior written consent of Excelitas Canada Inc. every effort has been made to ensure information in this manual is accurate, however, information in this manual is subject to change without notice and does not represent a commitment on the part of the authors.

### **Trademarks:**

OmniCure® is a trademark of Excelitas Canada Inc. All rights reserved. All other product names are trademarks of their respective owners. All product or software photos shown are for reference only and are subjected to change without notice.

Made in Canada. Doc. No. 035-00589R

## Revision History

Revision #	Comments
Rev 1.0	Initial release
Rev 2.0	Revised pins for enabling LED
Rev3.0	Release of new models
Rev 4.0	Updated regulatory section and corrections to technical tables
Rev 5.0	Updated to China RoHs guidelines

## Table Of Contents

<b>1</b>	<b>Introduction</b> .....	<b>1</b>
<b>2</b>	<b>Safety Precautions/ User Warnings</b> .....	<b>2</b>
2.1	Glossary of Symbols .....	2
2.2	Safety Precautions .....	2
<b>3</b>	<b>Optical Safety Data</b> .....	<b>4</b>
<b>4</b>	<b>Getting Started</b> .....	<b>5</b>
4.1	Packaging Contents .....	5
4.2	System Requirements .....	5
4.3	UV LED Head Images .....	6
4.4	Connecting the Power Supply and PLC Controller .....	7
4.5	Powering Up and Powering Down .....	8
<b>5</b>	<b>Mounting the UV Head</b> .....	<b>9</b>
<b>6</b>	<b>Connecting the UV LED Head</b> .....	<b>10</b>
6.1	Interfacing with the PLC .....	10
6.2	Integrating Monitoring with External Circuitry.....	11
<b>7</b>	<b>Using the LED Head</b> .....	<b>12</b>
7.1	Understanding the LED Indicators .....	12
7.2	Fault Status.....	12
<b>8</b>	<b>Troubleshooting</b> .....	<b>13</b>
8.1	Symptoms and Possible Causes.....	13
<b>9</b>	<b>Care and Maintenance</b> .....	<b>14</b>
9.1	Cautions and Handling .....	14
9.2	Cleaning Materials .....	15
9.3	Cleaning the LED Head .....	15
9.4	Cleaning the LED Head Air Intake .....	15
<b>10</b>	<b>Technical Specifications</b> .....	<b>16</b>
10.1	Environmental Conditions.....	16
10.2	UV LED Head Specifications .....	16
10.3	Regulatory Compliance.....	17
<b>11</b>	<b>Warranty</b> .....	<b>19</b>
11.1	Checking Your Warranty Status.....	19
11.2	Replacement UV LED Module Warranty .....	19
11.3	Returning your AC2- System to Excelitas Technologies for Service.....	19
<b>12</b>	<b>Contact Information</b> .....	<b>21</b>

## Figures

Figure 1 UV LED Head (front).....	6
Figure 2 UV LED Head (side, top).....	6
Figure 3 UV LED Head (back).....	6
Figure 4 PLC2000 Remote Control Console.....	7
Figure 5 PLC Connector (looking at UV Head).....	10
Figure 6 PLC digital output equivalent circuit.....	11

## Tables

Table 1 PLC Connector Pin Out.....	11
Table 2 LED Indicator Status (UV LED Head).....	12
Table 3 Environmental Conditions.....	16
Table 4: UV LED Head Specifications.....	16
Table 5 UV LED Warranty Status.....	19

## 1 Introduction

The OmniCure® AC2-series represents a new standard in UV LED curing systems. The series provides a very compact UV LED system with impressive power, irradiance uniformity, control and monitoring. The OmniCure® AC2-series systems are offered alongside a variety of power supply, controller and cabling options, providing configuration flexibility to suit any application for end users and integrators alike.

Optical output can be controlled via a PLC interface enabling a high degree of automation. At the heart of the OmniCure® AC2-series are the arrays of LEDs housed within the UV LED Head and located under the optical lens providing excellent spectral and power stability. The UV LED Head has a typical lifetime in excess of 20,000 hours of accumulated 'on' time, made possible by the integration of state-of-the-art electronics, effective thermal management and high performance optics. Acoustic noise is minimised through an innovative load-adaptive fan that keeps the LEDs operating efficiently and reliably while minimising the resultant noise levels.

In the Excelitas Technologies family of UV LED light systems, all systems offer the same high level of innovation, quality and reliability that our customers have come to expect. OmniCure® has combined next generation optical engineering, state-of-the-art electronics and fibre-optics to produce sophisticated technologies that employ light. Today, OmniCure® is a leading developer of light-based systems for sectors ranging from manufacturing to bio-medicine, and is unmatched in commitment to quality and service.

This manual covers the following models:

**AC275-365 - 019-00251R**

**AC275-395 - 019-00236R**

**AC275F-365 - 019-00270R**

**AC275F-395 - 019-00263R**

**AC2110-365 - 019-00271R**

**AC2110F-365 - 019-00272R**

**AC2110-395 - 019-00239R**

**AC2110F-395 - 019-00254R**

Excelitas Technologies recommends reading this guide to discover all features of the OmniCure® AC2-series Systems, and how to use them.

## 2 Safety Precautions/ User Warnings

### 2.1 Glossary of Symbols



Caution risk of danger – consult accompanying documents.



Risk Group

WARNING: UV emitted from this product. Avoid eye and skin exposure to unshielded product.

WARNING: Possibly hazardous optical radiation emitted from this product. Do not stare into operating lamp.



Input/ Output Signals



Input Signal



Caution, Hot Surface



Protective Conductor Terminal



Earth (Ground) Terminal



CAUTION, Risk of Electrical Shock

### 2.2 Safety Precautions

This series of cautions and warnings relate to the installation, operation and maintenance of the OmniCure® AC- System. They are also presented throughout this Installation/Reference Guide as applicable.



WARNING

Do not stare directly at the light emitted from the LED array. This may be harmful, resulting in eye injury.

Always use UV protective eyewear as indicated below. Additionally, protect any exposed skin with appropriate clothing or shielding as required.



Warning UV protective eyewear must meet the following recommended optical specifications:

- Spectral range; 350-440nm
- Optical Density  $\geq 6$



Warning Should the OmniCure® AC- System be used in a manner not specified by Excelitas Technologies, the protection provided by the equipment may be impaired.



The UV LED Head operation can be affected if handled incorrectly. Never touch the protective lens cover assembly of the UV LED Head. The presence of skin oils may result in a decrease in system performance.

## OmniCure® AC2 Series

UV Curing Solutions

---



Always ensure the power supply unit is turned off prior to disconnecting or re-connecting the UV LED Head.



Warning:

Monitoring the system during automated operation:

The level of UV energy supplied by the OmniCure® AC- System is sufficient to ignite flammable substances. Therefore, when the unit is operated unattended in an automated environment, an alarm function must be provided by the user to indicate a malfunction in the associated equipment used. During installation the appropriate measures must be included to prevent any such occurrence.



### 3 Optical Safety Data

IEC 62471: Photobiological Safety of Lamps and Lamp Systems

Resulting Classification and Labelling

Hazard	AC2xxx-395
Actinic UV	Risk Group 3
Near UV	Risk Group 3
Blue Light	Risk Group 1
Retinal Thermal	Exempt Group

<p><b>GROUPE DE RISQUE 3</b></p> <p><b>AVERTISSEMENT :</b> Ce produit émet des UV. Eviter d'exposer vos yeux et peau à un produit non blindé.</p> <p><b>ATTENTION :</b> Radiations optiques nuisibles peuvent être émises de ce produit. Ne pas fixer une lampe en cours d'utilisation.</p>		<p><b>RISK GROUP 3</b></p> <p><b>WARNING:</b> UV emitted from this product. Avoid eye and skin exposure to unshielded product.</p> <p><b>CAUTION:</b> Possibly hazardous optical radiation emitted from this product. Do not stare at operating lamp.</p>
---	--	---

IEC/TR 62471-2:2009

## 4 Getting Started

### 4.1 Packaging Contents

Your package contains one of the following UV LED Heads, as well as a documentation CD:

Model	Array Curing Width	Part Numbers
<b>AC275-365</b>	75mm	019-00251R
<b>AC275-395</b>	75 mm	019-00236R
<b>AC275F-365</b>	75mm	<a href="#">019-00270R</a>
<b>AC275F-395</b>	75mm	019-00263R
<b>AC2110-365</b>	110 mm	<a href="#">019-00271R</a>
<b>AC2110F-365</b>	110 mm	<a href="#">019-00272R</a>
<b>AC2110-395</b>	110 mm	019-00239R
<b>AC2110F-395</b>	110 mm	019-00254R

Carefully unpack the unit and store the packing material for future use.

### 4.2 System Requirements

In addition to the UV LED Head, you will require the following components:

- Power supply
- Power cable

You will also require a PLC controller unless you are using an existing controller. The PLC controller is used to discover the extensive functionality of the UV LED head. Integrators can access the full feature set through integrating with the PLC interface directly. Refer to [Section 6.1](#).

These may be sourced separately or may be purchased from Excelitas Technologies. Check with Excelitas Technologies to determine the appropriate components for your requirements. The following table provides the part numbers of component parts.

	AC275-365 / F	AC275-395 / F	AC2110-365 / F	AC2110-395 / F
System Controller	019-00199R	019-00199R	019-00199R	019-00199R
DC Power / Control Cable	018-00624R	018-00624R	018-00624R	018-00624R
PLC controller	014-00592R	014-00592R	014-00592R	014-00592R

Other units are available for different purposes; check with Excelitas Technologies to determine the appropriate components for your requirements.

# OmniCure® AC2 Series

UV Curing Solutions

## 4.3 UV LED Head Images



Figure 1 UV LED Head (front)



Figure 2 UV LED Head (side, top)



Figure 3 UV LED Head (back)

### 4.4 Connecting the Power Supply and PLC Controller

All connectors are via screw style fastener -- do not over tighten the connector screws.

**Note:** The following is a generic procedure, illustrated with the common components described above; please refer to specific documentation related to your power supply and controller.

**Tip:** After securing the power cable to the power supply, it is recommended to “tie-off” the female connector cable on to the mounting brackets or process rigging as a form of strain relief.

1. Make sure the power supply unit is turned off.
2. Connect the AC power cord to the power supply.
3. The PLC/Power cable has two legs connected to a shared female connector:
  - a) Attach the male end of the long leg to the power supply unit.
  - b) Connect the shared connector to the UV LED Head (see [Figure 2](#)).
  - c) Attach the female end of the short leg to the PLC I/O connector on the controller console (see [Figure 4](#)).
4. Connect the PLC loop-back connector to the PLC pass-through port (see [Figure 4](#)).
5. Power up the UV LED Head per [Section 4.5](#), and then push the LED Enable button on the controller to turn power on to the LED Head.
6. Adjust intensity using the up or down buttons to the right of the display (see [Figure 4](#)), to increase or decrease the intensity respectively. Refer to [Section 7](#), “Using the LED Head”.
7. UV LED & Temperature faults will be indicated by an illuminated LED on the control console. To clear, press the Clear Fault button (see [Figure 4](#)).



Figure 4 PLC2000 Remote Control Console

### 4.5 Powering Up and Powering Down



1. Ensure that the AC2- system has been properly installed, the protective blue covering has been removed from the optical window and the UV LED Head is securely mounted with the optical window in the desired orientation. Refer to [Section 5](#), “Mounting the UV Head”.
2. Verify that the power supply unit’s AC supply cord is connected to a properly grounded AC outlet.
3. If your power supply has a circuit breaker, switch it to the “ON” position.
4. Turn the main power switch of the power supply to the “ON” position and check the fan for airflow.
5. The LED indicator on the UV LED Head will *flash* green during “boot-up” and change to a *steady* green indicating UV LED Head is ready for use. It is recommended to wait for 1 minute from “cold state” to “ready state” before applying UV power to the Head. For more information about the indicators, see [Section 7.1](#), “Understanding the LED Indicators”.



After turning on UV power, the system will reach a fully stable operating temperature in 2-3 minutes. Caution – the UV LED Head can become very hot, avoid handling until the UV LED Head has cooled (approx. 5 min) or use protective gloves.

*Before disconnecting any cables, power down the UV LED Head using the PLC controller and turn off the power supply. (Note: the cooling fan may take up to 10 seconds to stop).*

## 5 Mounting the UV Head



**\*\*WARNING\*\***

*Do not block the air intake or the exhaust fans for the UV LED module's cooling system. Ensure that both intake and exhaust vents located on the LED heads have at least 2 inches (5cm) of clearance to allow sufficient air flow.*

The UV LED Head weights can be found in [Section 10.2](#)

The UV LED Head has four mounting holes on the back of the unit, M4 X 7mm deep. Refer to Figure 3.

For optimal performance, do not obstruct the air exhaust and air intake on the unit.

For detailed mechanical drawings, please refer to:

<http://www.excelitas.com/Pages/Product/OmniCure-AC-2-Series.aspx>



**\*\*CAUTION\*\***

*The threaded mounting holes incorporate a blind configuration; ensure that the appropriate length of mounting hardware is used. Attempting to install over-length mounting screws could damage the threaded mounting holes and internal components.*

## 6 Connecting the UV LED Head

### 6.1 Interfacing with the PLC

#### PLC Input Signal Requirements

	Digital	Analog
<b>Input</b>	<ul style="list-style-type: none"> <li>Voltage: 0 – 24V</li> <li>Current: 1 – 30mA</li> </ul>	<ul style="list-style-type: none"> <li>Voltage: 0 – 5V</li> <li>Current: 500uA</li> </ul>
<b>Output</b>	<ul style="list-style-type: none"> <li>Voltage: 0 – 5V</li> <li>Current: 2.5mA (max.)</li> </ul>	

#### PLC Connector Pin-Out

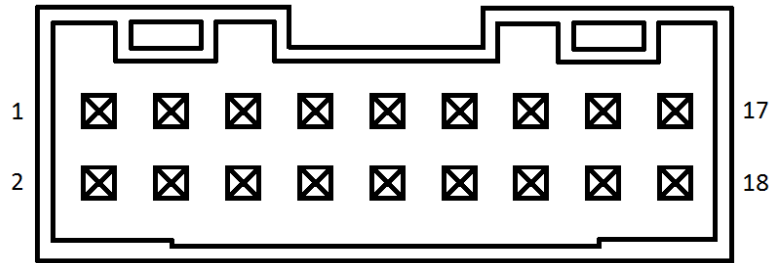

Figure 5 PLC Connector (looking at UV Head).

Refer to chart below for the pinout on the AC2 system. The connector type used is

Connector: JST S18B-PUDSS-1

Mating Connector: JST PUDP-18V-S

Pin No.	Signal Name	Description
1	General Fault	0.0 – 0.4V – General Fault
		2.4V – 5.0V – No Fault
2	Temperature Fault	0.0 – 0.4V – Temperature Fault
		2.4V – 5.0V – No Fault
3	Door Lock	0.0 – 0.4V – Enable
		Open - Disable
4	VCC	4.9V to 5.1V reference voltage.
5	Intensity	<~0.4V - Off
		~0.4V-1.0V – 20%
		1.0V –20%
		5.0V – 100%
6	PLC Ground	Reference ground for PLC signals.
7	LED on	0.0 – 0.4V – Indicates LEDs are off .
		2.4V – 5.0V – Indicates LEDs are on.
8	Enable	0.0 – 0.4V – Turns LEDS off.
		2.4 – 24.0V – Turns LEDS on.
9	TX	RS232
10	RX	

Pin No.	Signal Name	Description
11	+	Input +48 V;
12	-	
13	+	
14	-	
15	empty	Empty pin.
16	empty	Empty pin.
17	Chassis Ground	
18	Chassis Ground	

**Table 1 PLC Connector Pin Out**

## 6.2 Integrating Monitoring with External Circuitry

All inputs and outputs from the PLC interface are opto-isolated. The digital outputs are implemented using NPN logic. The equivalent circuit is shown in [Figure 6](#) below

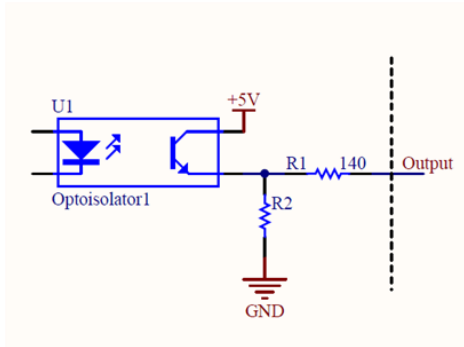

**Figure 6 PLC digital output equivalent circuit**



## 7 Using the LED Head

The peak wavelength of the UV LED Head is 395nm +/- 5nm.

For all models, adjusting the UV LED Head intensity can be actuated by an external controller via the PLC interface. Refer to [Section 6.1](#) for Pin-Outs.



Input voltage vs. desired intensity; 5V = 100% and 1V = 20%. A minimum voltage of 1V is required for light source operation.

**Note:** The light source will maintain a 20% intensity when the input voltage is in the range of ~0.5-1V. If the input voltage is below this, the light source will turn off.

Ensure the UV LED Head indicator is illuminated to a *steady* green before applying UV power to the head.

The UV LED Head indicator will illuminate to a *steady* amber indicating UV is on. When UV is off, the indicator will revert back to a *steady* green indicating UV is off.

The UV LED Head is capable of responding to PLC control signals in less than 0.2 seconds.

### 7.1 Understanding the LED Indicators

LED Indicator	Condition
Steady green	System Ready; no critical faults
Steady amber	UV LED turned ON
Steady red	Critical fault <ul style="list-style-type: none"> <li>• Temperature Fault</li> <li>• LED Fault</li> <li>• System Error</li> </ul>
Slow flashing green	POST and Initialization
Slow flashing red	Major or critical fault
Slow flashing amber	UV LED ON with major fault
Fast flashing green	Warranty status - operating hours is < 9000
Fast flashing amber	Warranty status - operating hours = between 9,000 and 10,000
Fast flashing red	Warranty status - operating hours is >10000

**Table 2 LED Indicator Status (UV LED Head)**

**Note:** To clear a fault or alarm signal, either cycle power to the LED Head or if connected to the PLC2000, press the Clear Fault button

**Caution:** Routine maintenance should only be completed by a user qualified personnel to avoid risk of injury to the end user. **No user serviceable components are located within the power supply or UV LED Head enclosures.**

### 7.2 Fault Status

#### PLC Output

- LED Fault: LED module fails to turn on.
- Thermal Fault that includes:
  - LED module temperature is over the maximum limit.
  - LED module temperature is lower than the minimum limit or open circuit.
  - Internal Fault.
  - Ensure air intake and exhaust are unobstructed and filter is unclogged. Refer to [Section 9.4](#)

## 8 Troubleshooting

### 8.1 Symptoms and Possible Causes

*Service to be completed by qualified Excelitas Technologies personnel only!*

*Always wear optical safety glasses while troubleshooting. Never put hands or fingers in front of the lens. Serious personal injury may result.*

*Do not place any potentially combustible materials (e.g. paper, card, etc.) in front of the LED Head. Risk of fire and damage to the UV LED Head may result.*

**If the system fails to power up:**

- Make sure the AC power cord is securely plugged into a functional AC outlet and into the AC inlet on the power supply unit.
- Make sure that the circuit breaker on the power supply unit is not tripped. If so, reset breaker.
- Make sure all cable connections (power supply to UV LED Head) are secure.
- Ensure that the power supply is switched on and the green LED indicator on the front panel is lit.

**If the system powers up but experiences a thermal fault during operation:**

- Ensure UV Head is installed with adequate clearance around intake and exhaust ports.
- Ensure intake air filter is not clogged or obstructed.
- If filter is clogged, either clean with compressed air or replace with a new filter insert.

**If the system powers up but does not emit UV:**

- Make sure the door lock electrical loopback on the PLC is installed properly.
- Ensure that the voltage levels on pins 3, 5 and 8 of the PLC interface match the logic required to enable the LEDs.
- Check the visual indicator for signs of a fault.

**If a fault condition has been detected:**

- Attempt to clear the fault by cycling power to the LED Head or by pressing the “Clear Fault” button on the PLC 2000 controller.

**If the system exhibits a fault condition with a slow-flashing red:**

- Power-cycle the UV Head to clear.

**If the light intensity is too low:**

- Make sure the input voltage is at least 46V (input voltage to the Head for the purposes of powering the head is typically 48V (46-50V DC)).
- Clean the optical window of the UV LED Head as described in Section 9.3, “Cleaning the LED Head”.
- Verify that the intensity level of the UV LED Head is set to the correct level, using the PLC Controller.

If problems persist beyond these troubleshooting points, please contact Excelitas Technologies Service Department (refer to [Section 12](#), “Contact Information”).

## 9 Care and Maintenance

**Note:** Excelitas Technologies recommends incorporating the cleaning of the optical window into the user/operator cleaning and maintenance schedule.

### 9.1 Cautions and Handling



**Caution:** Routine maintenance should only be completed by qualified personnel to avoid risk of injury/electrical shock to the end user. **No user serviceable components are located within the UV LED Head enclosure.**



**Warning:** Use UV radiation eye and skin protection during servicing if access to the UV LED modules is required during operation.

Risk Group 3 (IEC62471)

WARNING: UV emitted from this product. Avoid eye and skin exposure to unshielded product.

CAUTION: Possibly hazardous optical radiation emitted from this product. Do not stare into operating lamp.



**CAUTION UV:** Hazardous visible radiation is emitted from this product. Eye or skin irritation may result from exposure. Use appropriate shielding.

Ensure main power supply is disconnected prior to making any changes to cabling configurations.

Operate the unit in a well-ventilated area with at least 5 inches (12cm) clearance on both sides of the system power supply unit for proper air flow. Ensure that both intake and exhaust vents located on the LED heads have at least 5 inches (12cm) of clearance to allow sufficient air flow.

Avoid physical shocks or jarring of the LED Head, especially while the unit is operating.

When necessary, clean the optical window of the UV LED Head using an optical cleaning solution. Refer to [Section 9.3](#), “Cleaning the LED Head”.

The outer lens frame of the UV LED Head includes an optical window assembly. Improper handling and cleaning practices can damage polished surfaces or coatings which are utilized in this optical window. Note that damage to the surface of the glass or coating can degrade the unit’s performance. Proper handling and cleaning technique is very important. Below are the recommended procedures for cleaning of the OmniCure® UV LED Head optical window.

Always handle the UV LED Head by the metal enclosure; never touch the optical window with your fingertips. The moisture or oils on your fingertips can damage the coating of the lens window. Fingerprints left on an optical surface for an extended period of time, can become a permanent stain. Even if you are wearing gloves, avoid touching the optical surface.

Never handle the optical window with metal implements or tweezers.

Do not place the UV LED heads lens assembly onto a hard table-top surface; this can cause scratches in the window surface.

To store UV LED heads, wrap them individually in a clean, lint free bag and store in a safe place.

Never store unwrapped LED Heads together in a box or bag, as they may become damaged if they come in contact with each other.

### 9.2 Cleaning Materials

- Lint-free lens tissue, lint-free cotton swabs, lint or powder-free gloves or finger cots.
- An organic solvent, such as reagent-grade isopropyl alcohol, reagent-grade acetone, or lens cleaning solution.

### 9.3 Cleaning the LED Head



**\*\*WARNING\*\***

*Do not attempt to open the enclosure of the LED head. Ensure power to the power supply unit is OFF and the UV LED arrays are cool before attempting any cleaning procedure.*

Use protective gloves or finger cots suitable for the cleaning solution selected. Refer to the MSDS for guidance.

Turn off the UV LED head and keep the optical window, face down to prevent the solvent from seeping into the window during the cleaning procedure.

Blow off dirt and dust with pressurized air on front glass surface.

Use a lens tissue folded into quarters or a lint-free cotton swab. Saturate the lens tissue or swab with organic solvent as indicated in the cleaning materials section.



**\*\*CAUTION\*\***

*Before using any solvent, consult the manufacturer's Materials Safety Data Sheets (MSDS) and your internal Health and Safety Advisor for proper handling and storage.*

Using a new saturated tissue; clean optical window by gently wiping the surface with a continuous stroke in one direction.

**Note:** Never apply a dirty tissue or swab to the optical window of the UV LED Head.

**Note:** Never face the optical window upwards before the solvent has evaporated.

### 9.4 Cleaning the LED Head Air Intake



**\*\*CAUTION\*\***

*Ensure that the LED Head power cable is disconnected from the head assembly and the UV LED Head is cool to the touch.*

The air intake filter is located on the exterior of the LED Head (see [Figure 2](#)) and is removable for cleaning as required. Remove the filter frame by gently prying the frame from the clip end. Next, remove the filter media located within and clean with compressed air or the appropriate solvent as required.

Replace the filter and frame prior to powering up the LED Head.

## 10 Technical Specifications

### 10.1 Environmental Conditions

Operating Conditions	
Ambient Temperature	15°C to 30°C
Altitude:	3000m max.
Atmospheric Pressure:	700 to 1060 hPa
Relative Humidity:	10% to 80% (non-condensing)
Transport and Storage Conditions	
Temperature	-20 to +75°C
Relative Humidity	0% to 80% (non-condensing)
Atmospheric Pressure	500 to 1060 hPa

**Table 3 Environmental Conditions**

### 10.2 UV LED Head Specifications

Specification	AC275-365 / F	AC275-395 / F	AC2110-365 / F	AC2110-395 / F
Part number	019-00251R/019-00270R	019-00236R /019-00263R	019-00271R / 019-0272R	019-00239R/ 019-00254R
LED Peak Wavelength	365nm	395nm	365nm	395nm
Estimated LED Life	>20,000 hrs	>20,000 hrs	>20,000 hrs	>20,000 hrs
Typical Peak Irradiance	3.4W/cm <sup>2</sup> / TBD	4.1W/cm <sup>2</sup> / TBD	3.4W/cm <sup>2</sup> / TBD	4.1W/cm <sup>2</sup> / TBD
Variable Intensity Range	20 – 100%	20 – 100%	20 – 100%	20 – 100%
Typical Working Distances	3 mm (0.118 in)	3 mm (0.118 in)	3 mm (0.118 in)	3 mm (0.118 in)
Active Optical Area	5.9 mm x 76.2 mm (0.23 in x 3.0 in)	5.9 mm x 76.2 mm (0.23 in x 3.0 in)	5.9 mm x 114.3 mm (0.23 in x 4.5 in)	5.9 mm x 114.3 mm (0.23 in x 4.5 in)
Longitudinal Uniformity	+/- 10%	+/- 10%	+/- 10%	+/- 10%
Operating Voltage	48V DC +/-2V	48V DC +/-2V	48V DC +/-2V	48V DC +/-2V
Maximum Operating Current	2A	2A	2.92A	2.92A
Max Power Consumption	92 W	92 W	134 W	134 W
Weight	0.28kg (0.62 lbs)	0.28kg (0.62 lbs)	0.44kg (0.88 lbs)	0.44kg (0.88 lbs)
Dimensions (HxWxL)	129.4 mm x 28.6 mm x 78.8 mm (5.09 in x 1.13 in x 3.10 in)	129.4 mm x 28.6 mm x 78.8 mm (5.09 in x 1.13 in x 3.10 in)	139.1 mm x 28.6 mm x 117.5 mm (5.48 in x 1.13 in x 4.63 in)	139.1 mm x 28.6 mm x 117.5 mm (5.48 in x 1.13 in x 4.63 in)

**Table 4: UV LED Head Specifications**

## 10.3 Regulatory Compliance

### Regulatory Compliance

#### Product Safety and Electromagnetic Compatibility:

The OmniCure AC2 Series has been tested and found to comply with product safety and electromagnetic compatibility requirements. For a complete list of tests and for certification details, please contact your OmniCure representative or visit <http://www.excelitas.com/Pages/Product/OmniCure.aspx>

### CE Marking

Council Directive 2014/35/EU	Low Voltage Directive	
Council Directive 2014/30/EU	EMC Directive	
Council Directive 2012/19/EU	WEEE Directive	
Council Directive 2011/65/EU	RoHS	

### FCC Class A Digital Device or Peripheral – Information to User

#### Note:

This equipment has been tested and found to comply with the limits for a Class A digital device, pursuant to Part 15 of the FCC Rules. These limits are designed to provide reasonable protection against harmful interference when the equipment is operated in a commercial environment. This equipment generates, uses, and can radiate radio frequency energy and, if not installed and used in accordance with the instruction manual, may cause harmful interference to radio communications. Operation of this equipment in a residential area is likely to cause harmful interference in which case the user will be required to correct the interference at their own expense.

### WARNING

Changes or modifications not expressly approved by Excelitas could void the user's authority to operate the equipment.

### WEEE Directive (2012/19/EU)



The symbol above indicates that this product should not be disposed of along with municipal waste, that the product should be collected separately, and that a separate collection system exists for all products that contain this symbol within member states of the European Union.

- The equipment that you bought has required the extraction and use of natural resources for its production. It may contain hazardous substances that could impact health and the environment.
- In order to avoid the dissemination of those substances in our environment and to diminish the pressure on the natural resources, we encourage you to use the appropriate take-back systems. Those systems will reuse or recycle most of the materials of your end life equipment in a sound way.
- The crossed-out wheeled bin symbol indicated above invites you to use those systems.
- If you need more information on the collection, reuse and recycling systems, please contact your local or regional waste administration

## OmniCure® AC2 Series

UV Curing Solutions

---

### China RoHS



The symbol above indicates a product does not contain any restricted substances.

## 11 Warranty

Excelitas Technologies warrants the original purchaser for a period of one (1) full year, calculated from the date of purchase, that the equipment sold is free from defects in material and workmanship.

In the event of a claim under this warranty, the equipment is to be sent postage and carriage paid to the [Excelitas Technologies Service Centre](#). Returned equipment will not be received without a Return Authorization (RA) Number, issued by the appropriate Service Centre.

In order for us to serve you better, include a written description of the fault and the name and telephone number of a contact person who may be contacted for additional service related questions.

Any claims for units received with defects in material or workmanship must be reported to an authorized Excelitas Technologies Service Centre within 30 days from the original date of receipt and returned within 30 days of reporting to an authorized Excelitas Technologies Service Centre. Excelitas Technologies will repair or replace these reported defects free of charge. The equipment must be sent postage and carriage paid.

Package the equipment in its original shipping case or as appropriate to prevent damage during transport.

In the case of damage caused by wear and tear, careless handling, neglect, by the use of force or in the case of interventions and repairs not carried out by an Excelitas Technologies Authorized Service Centre, the warranty ceases to be valid. This warranty may not form the basis for any claims for damages, in particular not for compensation of consequential damages.

This warranty is not transferable.

**\*\*WARNING\*\***

*Apart from filters there are no field serviceable parts within the equipment.  
Opening the equipment main enclosure will void the warranty.*

### 11.1 Checking Your Warranty Status

You can check the status by pressing the Clear Fault button on the PLC 2000Controller. On release of the button the warranty status is indicated on the status indicator on the UV LED head.

The LED indicator on the UV Head will display the warranty status of the UV LEDs as follows:

LED Indicator	Condition
Fast Flashing Green	Operating hours is < 9000
Fast Flashing Amber	Operating hours = between 9,000 and 10,000
Fast Flashing Red	Operating hours is >10000

**Table 5 UV LED Warranty Status**

### 11.2 Replacement UV LED Module Warranty

If the AC2- system fails to power up during the warranty period of 10,000 operational hours, the UV LED Module will be replaced under warranty. In the event of a claim under this guarantee, the UV LED Head is to be sent postage and carriage paid, including a description of the fault, to the nearest appropriate [Excelitas Technologies Service Centre](#). Returned equipment will not be received without a Return Authorization (RA) Number, issued by the Service Centre. This warranty is non-transferable.

In the case of damage caused by careless handling, neglect, by the use of force or in the case of interventions and repairs not carried out by a Excelitas Technologies Service Centre Service Centre to the AC2- system, the guarantee ceases to be valid.

### 11.3 Returning your AC2- System to Excelitas Technologies for Service

Please make a note of the problem encountered, the steps followed to isolate the problem and the result of any trouble shooting steps taken.



## OmniCure® AC2 Series

UV Curing Solutions

---

Telephone the nearest Excelitas Technologies Service Centre to obtain a Return Authorization Number so that repairs may be completed quickly and efficiently. In North America, request for Return Authorization number can be made online at <http://www.excelitas.com/Pages/Support/Service-Instructions.aspx>.

Enclose details of the problem with the unit and return both to the Excelitas Technologies Service Centre. The unit should be returned in its original packaging if possible.

Include a phone number and contact person who may be reached for any additional service-related questions.

## **12 Contact Information**

Excelitas Canada Inc.  
2260 Argentia Road  
Mississauga, Ontario  
L5N 6H7 CANADA

Tel.: +1 905 821-2600

Toll: +1 800 668-8752 (USA and Canada)

Fax: +1 905 821-2055

<http://www.excelitas.com/Pages/Product/OmniCure.aspx>

### **Technical Assistance:**

[techsupport@excelitas.com](mailto:techsupport@excelitas.com)

<http://www.excelitas.com/Pages/Support/Service-Instructions.aspx>

For a complete listing of Authorized OmniCure Distributors and Service Centres please go to

<http://www.excelitas.com/Pages/Support/Service-Centers.aspx>.